

DESIGN AND TECHNOLOGY

Paper 1 Technology

6043/01

October/November 2015

2 hours 30 minutes

Additional Materials: Answer Booklet/Paper
 Plain paper
 Sketching equipment



READ THESE INSTRUCTIONS FIRST

Write your Centre number, candidate number and name on all the work you hand in.

Write in dark blue or black pen.

You may use an HB pencil for any diagrams, graphs or rough working.

Do not use staples, paper-clips, glue or correction fluid.

Part A

Answer **all** questions.

Part B

Answer **four** questions.

Answer **one** question from Section 1, **two** questions from Section 2, and **one** other question from either Section.

Use sketches where appropriate to help answer any question.

You are advised to spend no longer than 45 minutes on Part A and 1 hour 45 minutes on Part B.

At the end of the examination, fasten all your work securely together.

The number of marks is given in brackets [] at the end of each question or part question.

This document consists of **11** printed pages and **1** blank page.

Part A

You are advised to spend no more than 45 minutes on this part.

Attempt **all** questions.

- 1 Fig. 1 shows a large plastic key to be used as a shop sign.

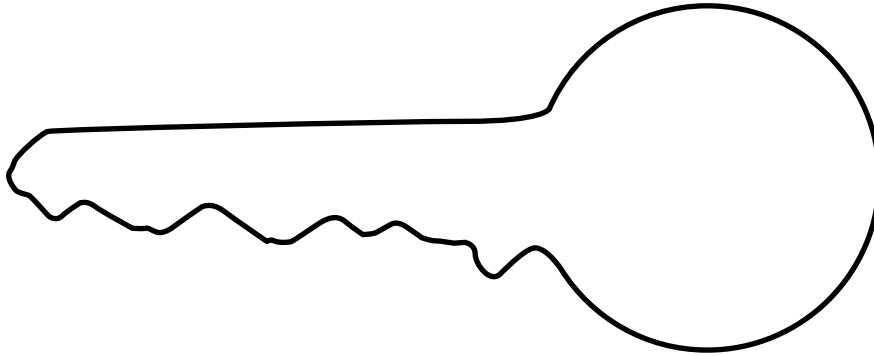

Fig. 1

Name **two** processes that could be used to make the key. [2]

- 2 Sketch the following tools;

(a) Pad saw;

(b) Junior hacksaw. [4]

- 3 Give **two** reasons for using a flux. [2]

- 4 Fig. 2 shows a piece of workshop equipment.

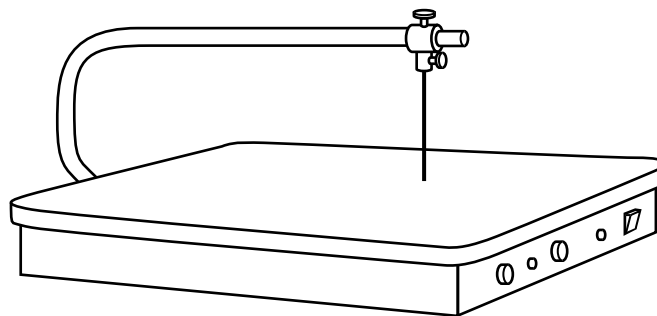

Fig. 2

(a) Name the equipment.

(b) State its purpose. [2]

- 5 Name **three** wood finishes. [3]
- 6 Explain the workshop term *annealing*. [2]
- 7 Fig. 3 shows a person sitting ready to work at a desk.

State **three** factors you would need to consider when designing the desk.

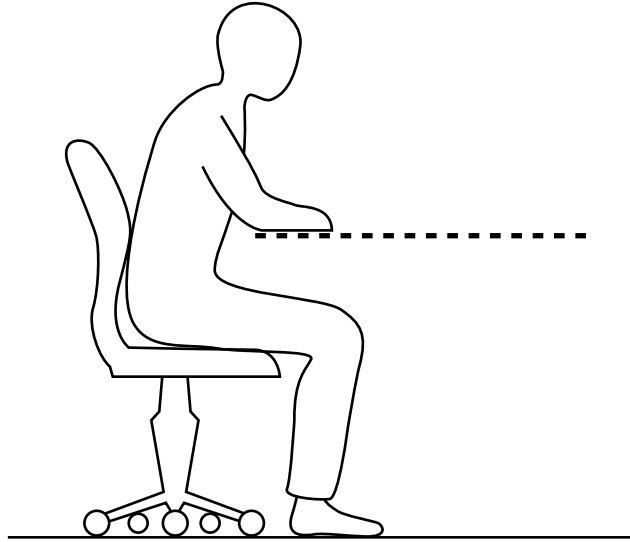

Fig. 3

[3]

- 8 State **three** ways of holding material on a wood turning lathe. [3]
- 9 Fig. 4 shows an aluminium drinks can.

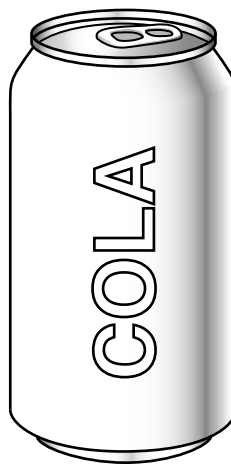

Fig. 4

Give **two** reasons why aluminium has been chosen for the can.

[2]

10 Name a suitable plastic for **each** of the following situations:

A insulated packaging for food;

B kitchen table surface;

C chair upholstery;

D illuminated sign.

[4]

Part B

You are advised to spend at least 1 hour 45 minutes on this part of the examination.

Attempt **four questions**, including **one** from Section 1, **two** from Section 2 and **one** further question from either section.

All questions carry equal marks.

Section 1 – Tools and Materials

11 Fig. 5 shows three different types of driving tool.

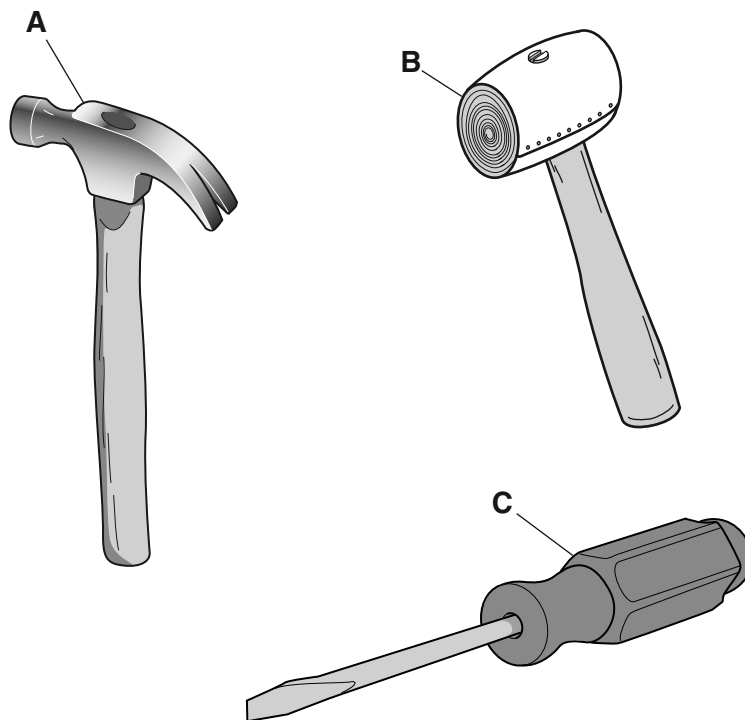

Fig. 5

- (a) Name each tool and state its purpose. [6]
- (b) Explain the reason for:
- (i) scrap wood used as an aid when using tool **A**;
 - (ii) using tool **B** instead of a wooden version;
 - (iii) tool **C** having an insulated handle. [6]
- (c) Sketch the following **two** tools.
- (i) nail punch;
 - (ii) pincers. [5]

12 The design for a drawer handle is shown in Fig. 6.

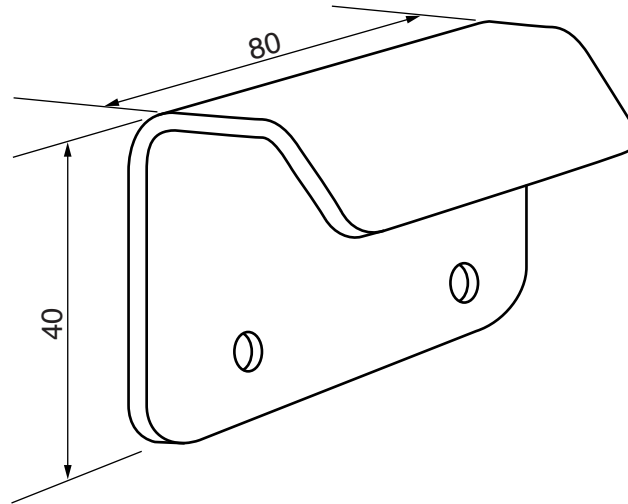

Fig. 6

(a) Materials being considered are:

- A Aluminium;
- B Beech;
- C Acrylic.

For each material give **one** reason for selecting and **one** reason for rejecting it as a suitable material for the handle. [6]

(b) Describe how heat or steam are used when forming the shape of the handle from **each** of the materials in (a). [6]

(c) Give the reason for:

- (i) rounding the corners of an aluminium handle;
- (ii) waxing the surface of a beech handle;
- (iii) paper or plastic film on the surface of acrylic sheet. [5]

- 13 Fig. 7 shows three products for which each of the materials has been modified during manufacture to improve its properties.

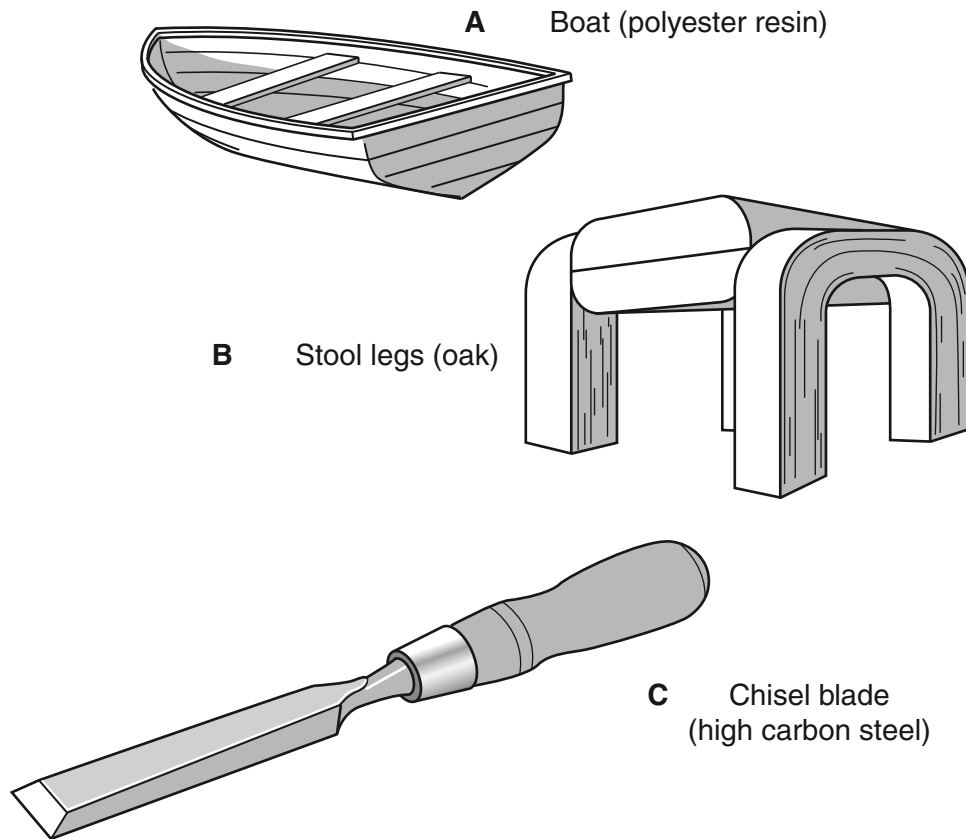

Fig. 7

- (a) Describe briefly how each of the materials in Fig. 7 has been modified to improve its strength. [6]
- (b) Explain how:
- (i) the smooth outside surface is achieved on the boat;
 - (ii) a former is used in the making of the chair legs;
 - (iii) incorrect grinding of a chisel blade can affect the strength of the cutting edge. [6]
- (c) State briefly how the following materials are improved by the addition of a second material:
- (i) blockboard has melamine sheet stuck to it;
 - (ii) mild steel has carbon added;
 - (iii) polyester resin has an accelerator added. [5]

Section 2 – Processes

14 Details of a single skittle are given in Fig. 8.

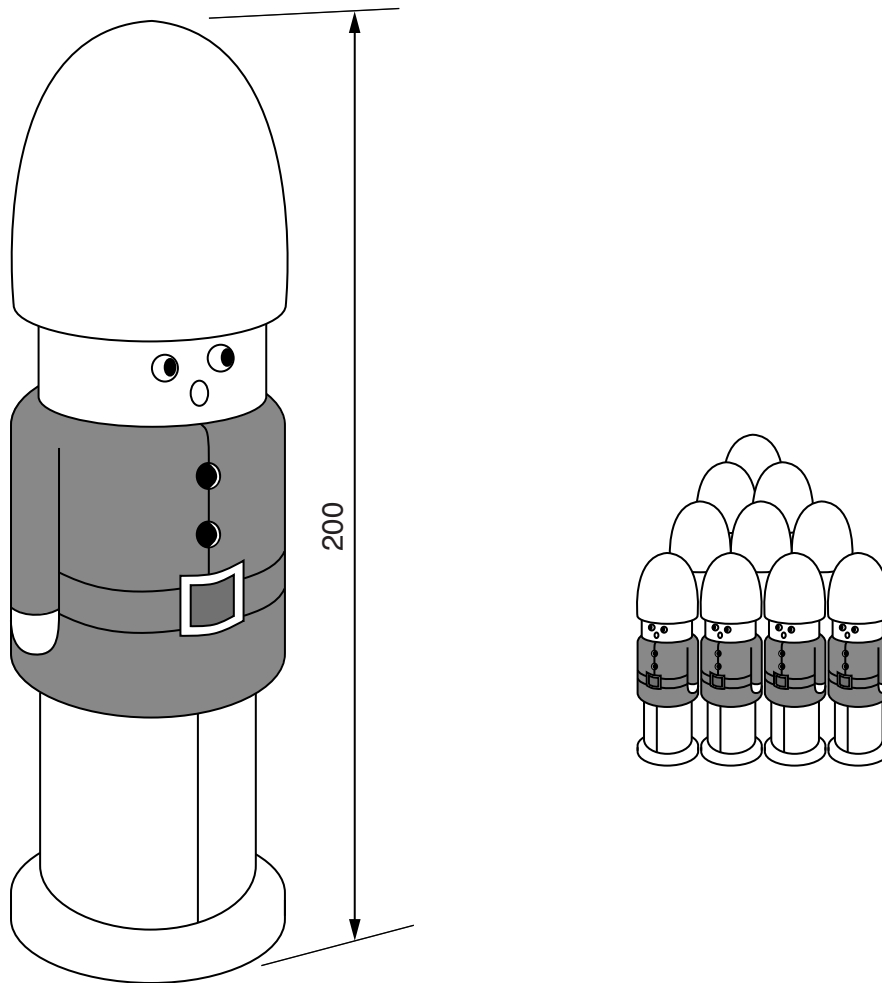
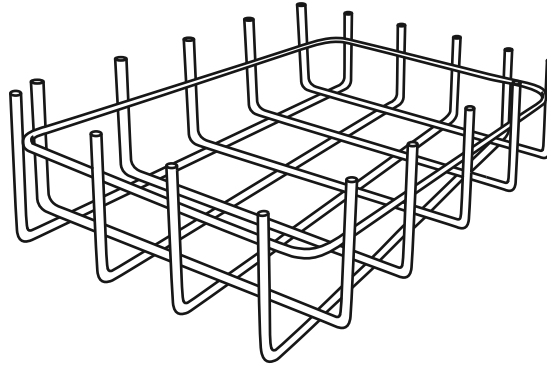

Fig. 8

- (a) State **two** properties that a material should have to be suitable for the skittle shown in Fig. 8. [2]
- (b) Describe, with the aid of notes and sketches, the making of a skittle using any **two** of the following methods:
- (i) injection moulding a plastic;
 - (ii) casting a light alloy metal;
 - (iii) turning on a wood turning lathe.
- [15]

15 Different processes are given in Fig. 9.

(a) Plastic coating a mild steel wire rack



(b) Marking out and cutting a finger joint

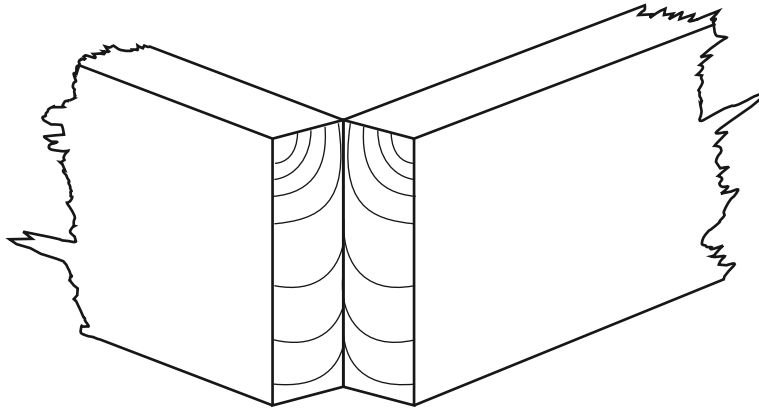

(c) Countersink riveting two mild steel plates together

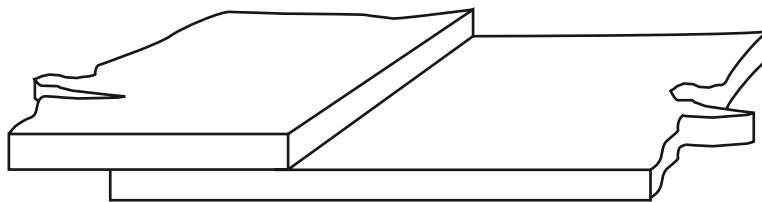

Fig. 9

Using notes and sketches describe how **two** processes are carried out.

[17]

16 Fig. 10 shows details of a winding device for the line of a kite.

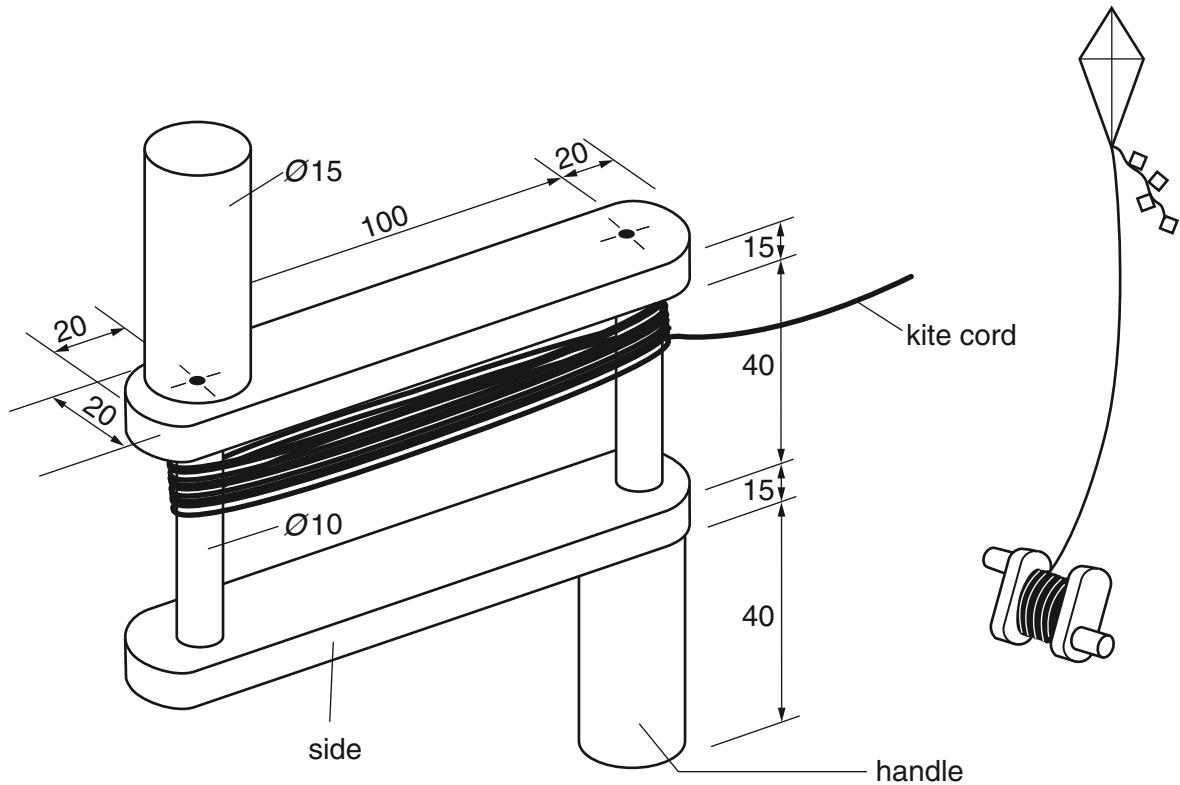

Fig. 10

- (a) State **two** properties required of a material for the winding device. [2]
- (b) State a suitable material for the winding device and use notes and sketches to give full details of the following:
- the stages of marking out the side pieces;
 - how the sides may be held and drilled to give true alignment of the holes;
 - how the handles may be joined to the sides. [13]
- (c) Show, by means of a sketch, how the handle could be improved for operation and safety. [2]

17 Fig. 11 shows the outline design for a model makers work station.

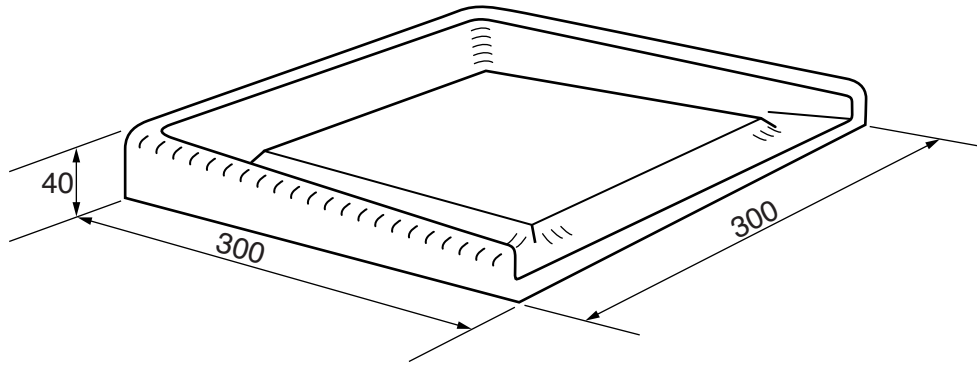

Fig. 11

- (a) Suggest a suitable material for the work station and give a reason for your choice. [2]
- (b) Name a method of manufacture and using notes and sketches, describe the major stages in making the work station. [9]
- (c) Show, by means of sketches, how the work station could be improved to accommodate small pots of paint, pencils, brushes. [6]
- 18 Explain what is meant by **each** of the following terms. Use notes and sketches to support your answers.
- A Soft soldering
- B Use of knock down fittings
- C Blow moulding
- D Knurling [17]

BLANK PAGE

Permission to reproduce items where third-party owned material protected by copyright is included has been sought and cleared where possible. Every reasonable effort has been made by the publisher (UCLES) to trace copyright holders, but if any items requiring clearance have unwittingly been included, the publisher will be pleased to make amends at the earliest possible opportunity.

To avoid the issue of disclosure of answer-related information to candidates, all copyright acknowledgements are reproduced online in the Cambridge International Examinations Copyright Acknowledgements Booklet. This is produced for each series of examinations and is freely available to download at www.cie.org.uk after the live examination series.

Cambridge International Examinations is part of the Cambridge Assessment Group. Cambridge Assessment is the brand name of University of Cambridge Local Examinations Syndicate (UCLES), which is itself a department of the University of Cambridge.